



Lot 23 Kitchen Finishes



Cabinet Color
(Hazel)



Cabinet Door Style
(rushmore)



Lot 23 Kitchen Finishes

PRO STORM

< Pro Frost / Tawny >

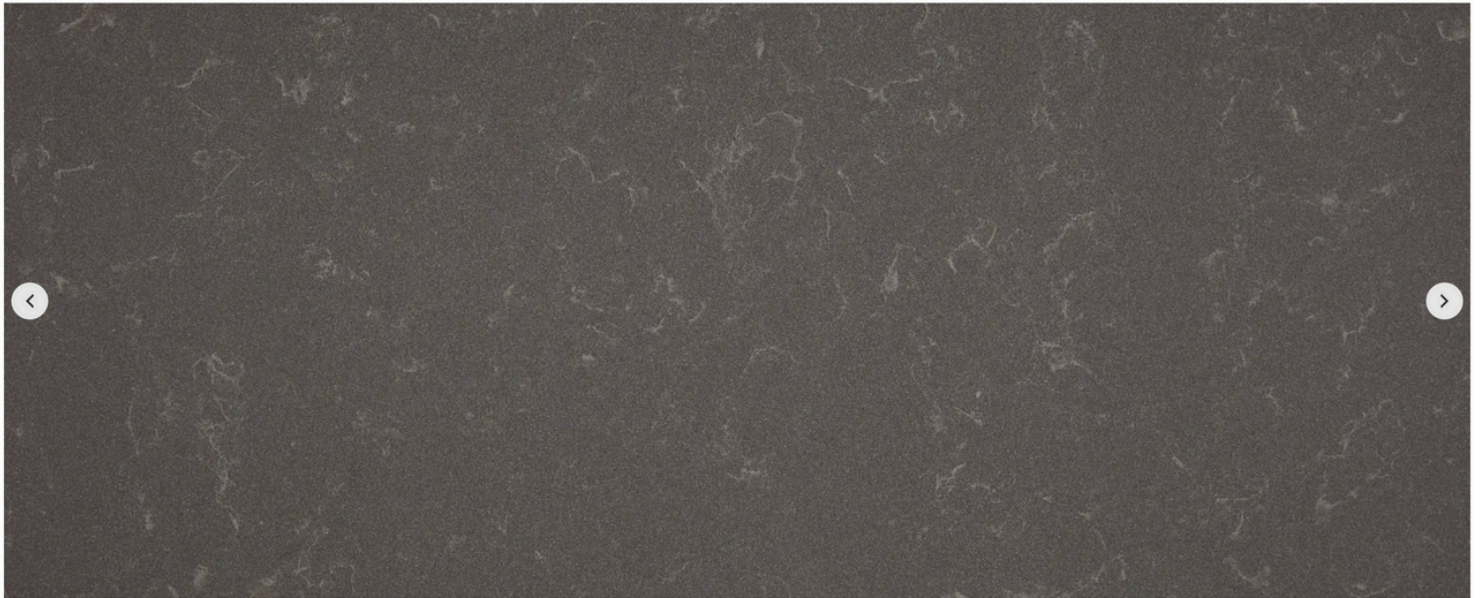

Countertop



Rewind polvere

Backsplash



Lot 23 Kitchen Finishes



Dinning
Room Lights



Kitchen Faucet



Lot 23 Kitchen Finishes

Appliance Packages

GE® ENERGY STAR® 22.1 Cu. Ft. Counter-Depth Fingerprint Resistant French-Door Refrigerator

Model #: GYE22GYNFS  4.1 (1735) | [Write a review](#)





Lot 23 Kitchen Finishes

Appliance Packages

GE® 30" Free-Standing Gas Range

Model #: JGB645SEKSS ★★★★★ 4.4 (546) | [Write a review](#)





Lot 23 Kitchen Finishes

Appliance Packages

GE® ENERGY STAR® Top Control with Stainless Steel Interior Dishwasher with Sanitize Cycle

Model #: GDT670SYVFS ★★★★★ 4.3 (4597) | [Write a review](#)





Lot 23 Kitchen Finishes

Appliance Packages

Karran
PRODUCT SPECIFICATION

Stainless steel 33" x 22-1/4"
Large Single Bowl Farmhouse Workstation Sink
Model: WSA-45-PK1

Karran Workstation Series stainless steel kitchen sinks are manufactured from durable 16 gauge stainless steel that makes them tough and resilient to even the toughest daily tasks. Each sink is finished with an elegant but durable soft satin brushed finish. This model is designed to be undermounted in all types of solid surface, granite and quartz countertops. The sink comes with a full complement of useful accessories for streamlining food prep and clean up.

Series:	Elite Workstation Series
Material:	16 Gauge, Type 304 stainless steel
Installation Type:	Undermount
Configuration / Style:	Single bowl farmhouse workstation
Finish:	Soft satin brushed finish
Overall dimensions:	33" x 22-1/4"
Bowl dimensions:	30" x 17" x 10"
Drain size:	3-1/2"
Min. cabinet size:	33"
Template included:	Yes
Clips included:	Yes
Accessories included:	Basket strainer, bottom grid, drying rack, cutting board

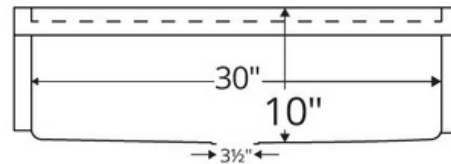
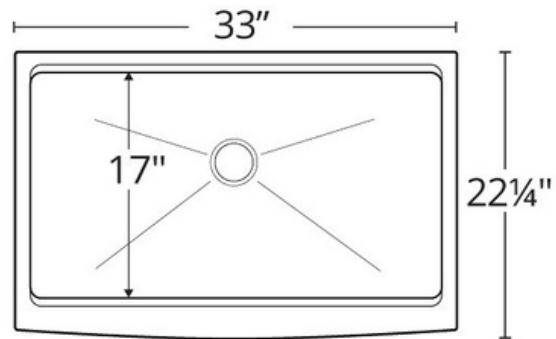

INSTALLATION PROFILE

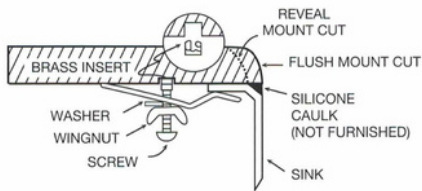

ACCESSORIES INCLUDED

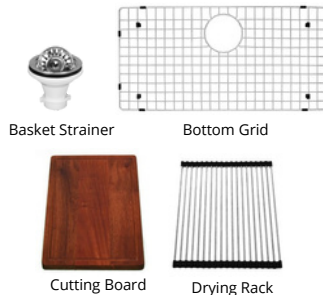

PROJECT INFORMATION	PROJECT:
_____	CONTACT:
_____	DATE:

NOTES: _____	

APPROVAL:	

We reserve the right to update product specifications without notice. Please visit karran.com for the most current specification sheets. All dimensions are accurate to 1/4". REV 05-2022